

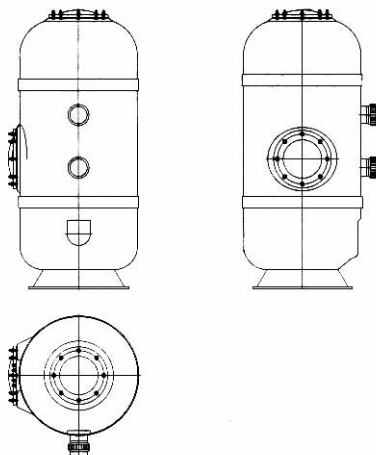

■ Multi Layer Laminated Filter, ST-series/
STL-series



TECHNICAL CHARACTERISTICS

ARTICLE NO.	DIAMETER	FLOW RATE m ³ /h	BED FILTRATION HEIGHT	FLOW RATE m ³ /h Speed	FILTRATION AREA, m ²	SELECTOR VALVE	SAND, Kgs	WEIGHT, Kgs	TOTAL HEIGHT
ST-9	610mm	9	1m	30	0,29	1½"	475	52	1.550mm
ST-14	765mm	14	1m	30	0,45	1½"	650	66	1.600mm
ST-20	910mm	20	1m	30	0,65	2"	925	88	1.750mm

ARTICLE NO.	DIAMETER	FLOW RATE m ³ /h	BED FILTRATION HEIGHT	FLOW RATE m ³ /h Speed	FILTRATION AREA, m ²	SELECTOR VALVE	SAND, Kgs	WEIGHT, Kgs	TOTAL HEIGHT
STL-9	610mm	9	1,2m	30	0,29	1½"	575	69	1.750mm
STL-14	765mm	14	1,2m	30	0,45	1½"	800	85	1.800mm
STL-20	910mm	20	1,2m	30	0,65	2"	1.125	110	1.950mm